

# Development of research reactor simulator and its application to dynamic test-bed

**KWON Kee-Choon<sup>1</sup>, BAANG Dane<sup>1</sup>, PARK Jae-Chang<sup>1</sup>, LEE Seung-Wook<sup>1</sup>, and BAE Sung Won<sup>1</sup>**

*1. Korea Atomic Energy Research Institute, 989-111 Daedeok-daero, Yuseong-gu, Daejeon, 305-353, Rep. of Korea (kckwon@kaeri.re.kr)*

**Abstract:** We developed a real-time simulator for “High-flux Advanced Neutron Application ReactOr (HANARO), and the Jordan Research and Training Reactor (JRTR). The main purpose of this simulator is operator training, but we modified this simulator into a dynamic test-bed (DTB) to test the functions and dynamic control performance of reactor regulating system (RRS) in HANARO or JRTR before installation. The simulator hardware consists of a host computer, 6 operator stations, a network switch, and a large display panel. The software includes a mathematical model that implements plant dynamics in real-time, an instructor station module that manages user instructions, and a human machine interface module. The developed research reactor simulators are installed in the Korea Atomic Energy Research Institute nuclear training center for reactor operator training. To use the simulator as a dynamic test-bed, the reactor regulating system modeling software of the simulator was replaced by actual RRS cabinet, and was interfaced using a hard-wired and network-based interface. RRS cabinet generates control signals for reactor power control based on the various feedback signals from DTB, and the DTB runs plant dynamics based on the RRS control signals. Thus the Hardware-In-the-Loop Simulation between RRS and the emulated plant (DTB) has been implemented and tested in this configuration. The test result shows that the developed DTB and actual RRS cabinet works together simultaneously resulting in quite good dynamic control performances.

**Keyword:** research reactor simulator; reactor regulating system

## 1 Introduction

High-flux Advanced Neutron Application ReactOr (HANARO) is a multi-purpose research reactor at the Korea Atomic Energy research Institute, and has been operated since 1995. The Jordan Research and Training Reactor (JRTR), a 5MW multipurpose research reactor is being developed for Jordan University for Science and Technology, 67Km north of Amman. Training and retraining programs using a simulator for the operating staff, including reactor manager, shift supervisors, reactor operators, and others working at the research reactor facility has been required before actual operation. We developed two real-time simulators for the HANARO and JRTR research reactor, respectively for operating staff training to satisfy these programs <sup>[1,2]</sup>. The main purpose of these two simulators are operator training, but we modified this simulator as a dynamic test-bed to test the upgraded reactor regulating system in HANARO and JRTR before installation.

## 2 Research reactor simulator

### 2.1 Simulator configuration

The simulator configuration is divided into hardware and software. The simulator hardware consists of a host computer (DELL Precision T5500, Window 2008 Server), 6 operator stations, a network switch, an instructor station, and a large display panel as shown in Fig. 1. The HANARO/JRTR hard-wired panel is not replicated, and is replaced by a soft panel. The HANARO simulator and JRTR simulator use the same hardware platform.

The simulator software is divided into three major parts: a mathematical modeling module, which executes the plant dynamic modeling program in real-time, an instructor station module that manages user instructions, and a human machine interface (HMI) module as a graphical user interface. Fig. 2 shows the simulator software configuration <sup>[3]</sup>.

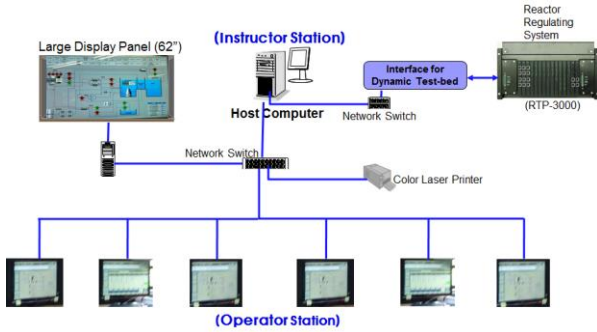

Fig. 1 HANARO simulator hardware configuration.

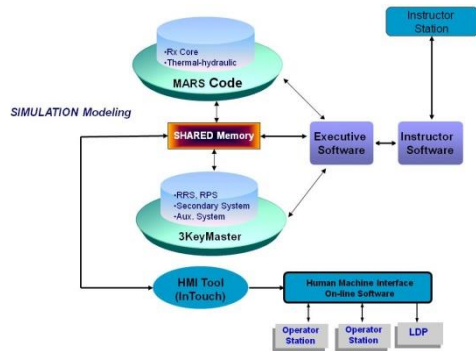

Fig. 2 HANARO simulator software configuration.

### 2.2 Mathematical modeling

The HANARO research reactor is an open-tank-in-pool type with 30MWth power capacity. HANARO consists of a reactor core, primary cooling system including a reactor pool, a primary cooling water purification system, a reflector cooling system, an emergency water supply system, a spent fuel pool cooling and purification system, a secondary cooling system, and a hot water layer system.

The mathematical model has been implemented using two different kinds of software. The reactor core and thermal-hydraulics of the primary cooling system (PCS) including the reactor pool are modeled using a Multi-dimensional Analysis of Reactor Safety (MARS™) code. Fig. 3 shows the MARS input nodalization of the JRTR PCS. The JRTR PCS input consists of a primary loop, and pool systems. First, the primary loop is a closed loop combined with the reactor vessel including the fuel core, pumps, heat exchangers, and connecting pipes. Second, the pool system designates the large water pool in which the JRTR reactor vessel is merged. Because the JRTR is an open-type cooling system, the core outlet plenum is

a free mix-up zone of the core outlet flow and pool water. The balance of the plant and control/protection logics are modeled using 3KeyMaster™.

MARS is a best-estimate system thermal hydraulics code with multi-dimensional capability [4]. 3KeyMaster is a commercial fully integrated simulation environment that provides real-time executive, instructor station software, and simulation modeling tools as shown in Fig. 5. 23 system malfunctions are selected based on an emergency operating procedure and abnormal operating procedure. In addition, the simulator provides each component malfunction modeled by 3KeyMaster™.

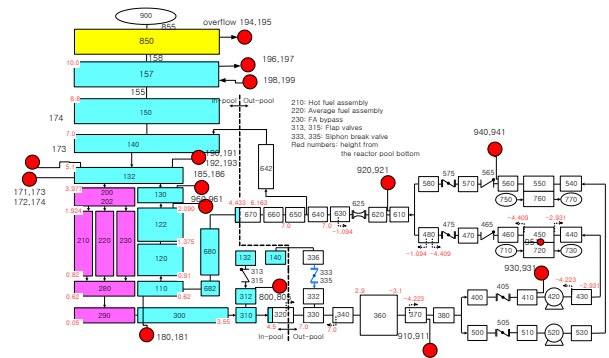

Fig. 3 MARS code nodalization for primary cooling and pool systems.

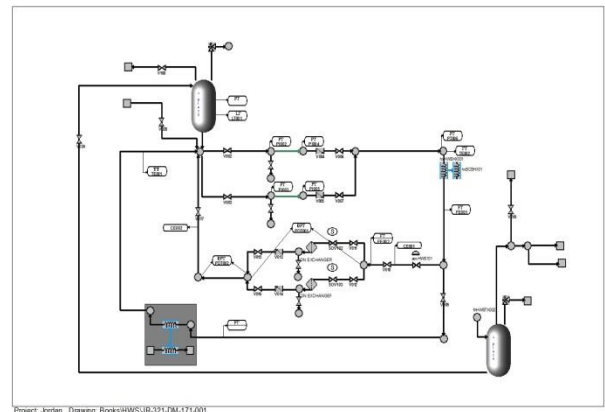

Fig. 4 Heavy water system dynamic model using 3KeyMaster.

### 2.3 Human-Machine Interface (HMI)

The HANARO simulator provides two kinds of HMI for the trainees. One is Operator WorkStation (OWS), which is functionally the same as the reference research reactor HANARO/JRTR, the other is a large display panel that provides the overall status of HANARO/JRTR and alarms, as shown in Figs. 5 and 6. The HMI display pages are developed by the

InTouch™ commercial graphic tool which is used in the real HANARO plant.

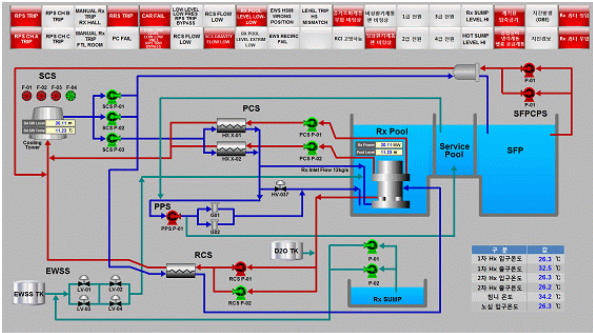

Fig. 5 Large display panel in HANARO simulator.

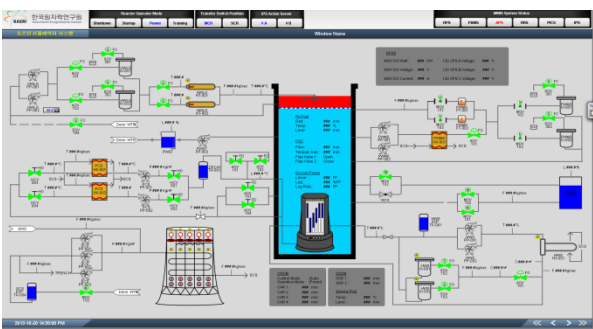

Fig. 6 Large display panel in JRTR simulator.

**2.4 Instructor station**

The instructor station consists of a status bar which displays the malfunctions, remote functions, and major parameters; a control panel for instructor actuation; and a graphic display area, as shown in Fig. 7. The instructor station comprises all instructions that should be necessary for running the simulator. This instructor station provides several types of instructions, such as run/freeze, reset, snapshot, backtrack, insert system or component malfunction, execute remote function, etc.

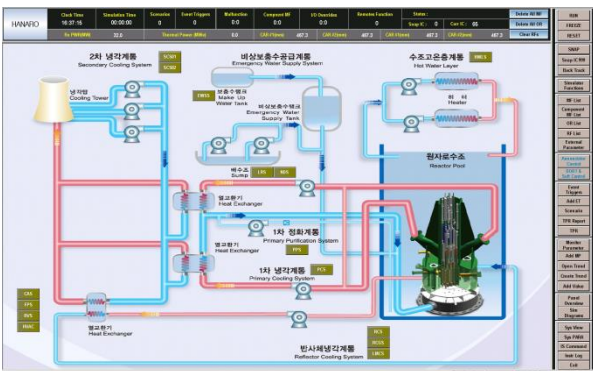
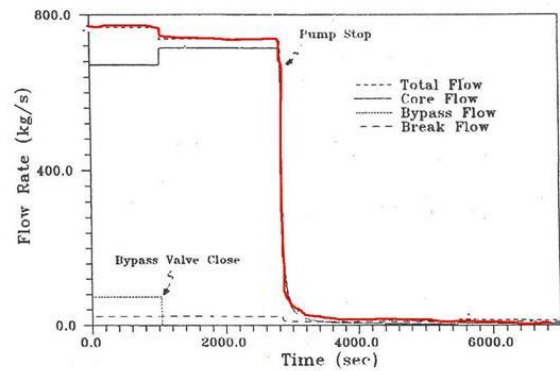

Fig. 7 Main display page of instructor station.

**2.5 Validation**

The developed simulator is validated by the HANARO operator according to normal, abnormal, and emergency operating procedures. HANARO operators issued lots of discrepancy reports of which were resolved during the integration test. A comparison of the test results of the loss of coolant accident by a rupture of the reactor inlet pipe is shown in Fig. 8. The break size of the HANARO safety analysis is  $9.67 \times 10^{-4} m^2$ , and the break size of the simulator is 25% of the full leak size.



Result of HANARO safety analysis



Result of HANARO simulator

Fig. 8 Coolant flow when a loss of coolant accident occurs by a rupture of the reactor inlet.

**3 Dynamic test-bed**

As the main function of RRS is reactor power control, the test equipment for RRS shall include reactor model that runs reactor dynamics based on RRS command, and generates feedback signals for RRS (neutron detector signals and Control Absorber Rods (CAR) positions, for example) in real-time.

Therefore, to implement DTB, the RRS software part of the JRTR simulator was replaced by actual RRS cabinet as shown in Fig. 9 and 10 while the other reactor models remains the same. In result, the DTB consists of a PC including mathematical models for JRTR, and a Distributed Control System (DCS) that handles hardwired and network interface between the PC and RRS cabinet. The purpose of DTB test is to check the integrity of all functions of actual RRS cabinet under hard-wired environment, using the emulated signals provided by DTB.

This kind of Hardware In the Loop Simulation (HILS) test is useful especially to verify that

- Whether or not the supplier implemented RRS cabinet correctly
- Signal property check, networking and hard-wired communication integrity check, and noise-handling functions of RRS (for hard-wired signals)

For the simplicity of test, some important signals such as neutron detector output and CAR positions, have been selected for hard-wired connection amongst about 130-number of actual hard-wired signals for RRS. The other signals have been emulated and transmitted via network by DTB.

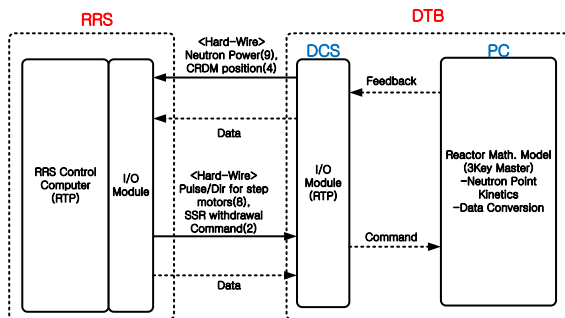

Fig. 9 Configuration of DTB test.

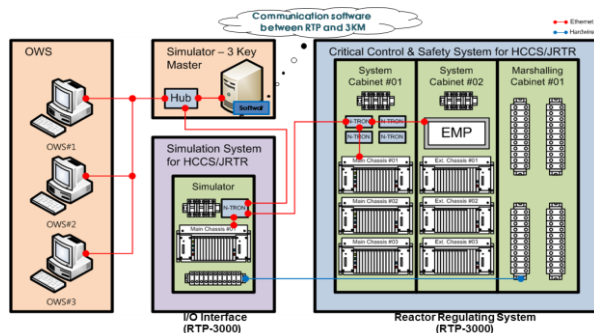

Fig. 10 Interface with simulator and controller.

The sequence of test was defined as follows. In normal operation, the routine reactor operation sequence has been followed by manipulating RRS software variables and DTB variables, and the related RRS functions have been checked. In abnormal case test, several failure cases have been emulated and the related RRS functions such as alarm and setback, have been tested.

### Normal operation

- Shutdown Reset
- SSR(Second Shutdown Rod) withdrawal
- Manual Control of CARs
- Control Mode Switching (Manual → Auto)
- Power Ascension and Full Power Operation
- Reactor Trip and Drive-Rod-In

### Abnormal cases

- Invalid Operator Input
- Large Discrepancy between calculated vs. sensed position of CARs
- Neutron Detector Failure
- RRS setback
- One CAR withdrawal accident
- Operating Bypass Switch
- Failure in RRS cabinet
- Activating Training Mode
- Rod Drop Test

Another important property to check is dynamic control performance. In the power ascension test, it has been shown that RRS can regulate reactor power based on operator input(power demand) with maximally 3% of overshoot at full power operation (See Fig. 11). As the trip setpoint of reactor protection system is quite larger than this value, we concluded that all RRS functions including dynamic control performance are acceptable for JRTR.

In result, the set of nominal parameters for RRS has been obtained by this test, but some parameters such as the gain for closed-loop power control logic, can be more-accurately tuned after installation at site.



RRS control output (Filter off)



Results of control logic tuning(Filter off)



RRS control output (Filter on)

Fig. 11 Test results of RRS control algorithm using a dynamic test-bed

## 4 Conclusion

We developed the HANARO/JRTR simulators the MARS code and 3KeyMaster simulation platform. Then, the training simulator has been modified to a dynamic test-bed by replacing the RRS software part with the actual RRS cabinet and adopting a DCS for interfacing. The functions and the control performance of the developed RRS cabinet have been tested showing reasonable and acceptable results.

## References

- [1] ANSI/ANS-3.5-2009, Nuclear Power Plant Simulators for Use in Operator Training and Examination, 2009.
- [2] DE CARVALHO Richardo Pinto and MAIORINO Jos é Rubens, "A Research Reactor Simulator for Operators Training and Teaching," PHYSOR-2006, ANS Topical Meeting on Reactor Physics, Vancouver, Canada, September 10-14, 2006.
- [3] KWON Kee-Choon, KIM Jang-Yeol, PARK Jae-Chang, and LEE Seung-Wook, In-Ah Hwang, Dong-Young Lee, "Development of the HANARO Research Reactor Simulator for Operator Training," Transactions of the Korean Nuclear Society Autumn Meeting, Gyeongju, Korea, October 25-26, 2012.
- [4] KAERI/TR-2811/ 2004, MARS 3.0 Code Manual, Korea Atomic Energy Research Institute, 2004.