

Analog computation dedicated for simulation of combined electrolysis catalytic exchange (CECE) process for water detritiation

WANG Yan¹, JIAO Caishan¹, SUN Yandong¹, and ZHU Rongkai²

1. College of Nuclear Science and Technology, Harbin Engineering University, Number 145, Nantong Street, Harbin 150001, China (18846453784@163.com)
2. College of Material Science and Chemical Engineering, Harbin Engineering University, Number 145, Nantong Street, Harbin 150001, China (zrk@hrbeu.edu.cn)

Abstract: The main purpose of this paper is to realize the analog computation of water-hydrogen liquid phase catalytic exchange process. Two transfer mathematical models of liquid phase catalytic exchange column, related to the types of the catalytic filling (mixed or separated), is presented, which can describe the mass transfer process of tritium isotope from water or heavy water to hydrogen and vice versa. The simulation results show that mixed bed has better mass transfer coefficient for liquid phase catalytic exchange column and agree with other researchers' findings well.

Keyword: combined electrolysis catalytic exchange (CECE); liquid phase catalytic exchange (LPCE)

1 Introduction

In the pressurized water reactors and heavy water reactors, water or heavy water used as the reactor coolant and moderator are irradiated by neutron, which leads to the production of tritium. It is a kind of weak beta radiation, with a half-life of 12.4 years. Once entering the body, tritium will cause serious internal radiation damage, so the control of tritium content in the workplace and water environment is very strict. Besides, the production of fusion energy requires huge amounts of tritium, which is about $1.5 \times 10^{19} \text{Bq} \cdot \text{GW}_{\text{th}}^{-1} \cdot \text{a}^{-1}$. Therefore, separation of hydrogen isotopes is necessary.

Recently, in order to achieve the purpose of separating hydrogen isotopes in water, the combined electrolysis catalytic exchange (CECE) process has been selected for most of experiments and pilot plants as a proven technology. The fundamental principle of CECE process is isotopic exchange between liquid water and gaseous hydrogen based on the preference of hydrogen isotopes remaining in the liquid phase: tritium > deuterium > protium².

Because tritium is radioactive substance and the operation of verified experiment is difficult. The

simulation studies are particularly important. As well as comprehensive numerical simulation method is adopted to optimize design, improve performance and support operation for CECE process, which will offer enough tools for the evaluation of the CECE system and description of the complicated mass transfer between three hydrogen isotopes².

Since 1980s, some relevant technical studies have been carried out in, including Russia, Romania and Canada, *etc.* The experimental studies and simulation researches provided a lot of data supporting the CECE system running, debugging and equipment design. Moreover, a number of simulation softwares were developed for CECE, such as SICA³, EVIO⁴ and FLOSHEET⁵.

SICA is multi-function software, designed to be used in liquid phase catalytic exchange (LPCE) process simulation, which is developed by National Research and Development Institute for Cryogenics and Isotopic Technologies (ICIT), in Romania. The software, written in C++ programming language, can calculate the mass transfer of H, D or T isotope from liquid to gas and vice versa. The software accomplishes calculations based on the package type,

Received date: March 22, 2018
(Revised date: May 28, 2018)

which can be applied to the equipment design and research on experimental operation.

A simulation software-FLOSHEET is developed by Canada Ontario Hydro, which can be used for simulation analysis of hydrogen isotopes separation and fusion fuel processing systems. It is groundbreaking software that adopts graphical interface (GUI) to write the program. FLOSHEET can provide support for the operation of Darlington Tritium Removal Facility at Darlington Nuclear Power Plant A.

To verify the experimental data and optimize equipment design, Petersburg Nuclear Physics Institute developed a simulation calculation program called "EVIO", whose latest version is "EVIO-5". The program can calculate the mass transfer of the heavy hydrogen elements between three phases (liquid, gas and vapor) with the improved mathematical model of technological process. "EVIO-5" is able to determine the optimal operating parameters of the experiment system, propose amendments for process operation, optimize equipment design and reduce experiment workload.

In this research, two mathematic models are established which are related to the types of the catalytic filling (mixed or separated). The models can describe the transfer of tritium isotope from water or heavy water to hydrogen and vice versa. We could compare the mass-transfer characteristics of different types of filling and verify the correctness of mass transfer process mechanism from water to hydrogen.

2 Description of the process

The combined electrolysis-catalytic exchange (CECE) is a compound process that includes hydrogen-water isotope chemical catalysis exchange and electrolysis. The CECE process uses high-performance hydrophobic catalyst and hydrophilic packing and can be considered as a more flexible and more efficient alternative for hydrogen isotopes separation [3][5]. The CECE facility consists of two main parts: the electrolysis cell and the (LPCE) column which is the key element. The dry and mass flow controlled tritiated hydrogen is produced by electrolytic dissociation of tritiated water. Firstly, hydrogen passes

through LPCE column that is controlled by countercurrent trickle bed reactor which contains hydrophobic catalyst and hydrophilic packing. Secondly, the liquid water of known tritium concentration is fed into the top of the column at a given G/L ratio. The liquid phase gets enriched in tritium during downward trickling along the LPCE column. Hydrogen gas is depleted after passing through the layer bed.

2.1 Principle of tri-phase mass transformation

The reaction of the isotopic exchange process between water and hydrogen consists of two elementary reactions which are phase exchange reaction(*d*) and catalytic exchange reaction(*c*) respectively. The equilibrium is determined by equilibrium constant of reversible reaction [7]. As written in Eq. 1, hydrogen(*g*) and vapor(*v*) participate in catalytic isotopic exchange, which occurs in co-current flow. As written in Eq. 2, isotopes also participate in phase exchange between vapor(*v*) and liquid water(*l*), which proceeds in counter-current flow.

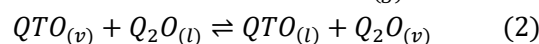
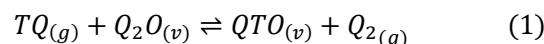

The overall process can be described as Eq. 3.

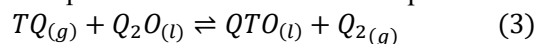

Where: *Q* stands for light isotope of hydrogen (H or D).

2.2 Models of mass transfer

Shimizu *et al.* [7] built a tri-phase mass transfer model for T separation in the LPCE and developed analytical solutions for limiting cases at low concentration. The steady-state mass transfer model of species *i* (*i*=T) in LPCE column can be described by the coupled differential equations (Eq. 4- Eq. 6) :

$$L \cdot \frac{dx_i}{dh} = K_d A_d [x_i - x_i^*] = K_d A_d [x_i - \alpha_d v_i] \quad (4)$$

$$V \cdot \frac{dv_i}{dh} = K_c A_c [v_i - \alpha_c y_i] - K_d A_d [x_i - \alpha_d v_i] \quad (5)$$

$$G \cdot \frac{dy_i}{dh} = K_c A_c [v_i - v_i^*] = K_c A_c [v_i - \alpha_c y_i] \quad (6)$$

Where, K_d and K_c are mass transfer coefficients of catalytic isotopic exchange and phase exchange ($\text{mol} \cdot \text{m}^{-3} \cdot \text{s}^{-1}$). x_i, y_i, v_i respectively are the atom fraction of species in the liquid phase, gas phase and vapor phase. L, G, V are the liquid, gas and vapor flows ($\text{mol} \cdot \text{s}^{-1}$). A_d, A_c are the response areas.

x_i^* and v_i^* are equilibrium atom fraction of species i in liquid and vapor. When concentration is low (below 5%), the equilibrium atom fraction can be simplified by separation factors (α_d, α_c). The separation factors depend on temperature and species isotopic.

2.3 Models of mass transfer coefficients

The mass transfer coefficients of gaseous and liquid phases isotopic exchange is represented by traditional method, which is mass transfer rate of unit packing volume [8]. Experiments are carried out using the liquid-phase reaction setup, measuring the height of mass transfer unit and the tritium concentration in the vapor and liquid at the inlet and outlet of the column. The mass transfer coefficient is determined by Eq. 7.

$$K_d = \frac{V}{A_d h_{oy}} \quad (7)$$

The height of mass transfer unit (h_{oy}) is defined as Eq. 8. The p value representing the attained degree of phase exchange is determined by Eq. 9.

$$h_{oy} = h_{eq} \frac{\alpha_d - p}{\alpha_d} / \ln\left(\frac{\alpha_d}{p}\right) \quad (8)$$

$$p = \frac{x_{in} - x_{out}}{v_{in} - v_{out}} \quad (9)$$

To describe the kinetics of catalytic isotopic exchange reaction, homogeneous reaction model is used. The models are simplified by employing parameters, such as the rate of mass transfer between liquid water and water vapor, which is usually measured in an experiment carried out in a gas-phase reactor filled with a sample layer of lyophobic catalyst. A mixture of hydrogen and vapor flows through the layer and the isotopic compositions is measured at the outlet of the layer. The rate of mass transfer of the isotopic exchange reaction is described by Eq. 10 [10].

$$k_c = -\frac{1}{\tau} \cdot \ln(1 - F) \quad (10)$$

The F value representing the attained degree of catalytic exchange is determined by Eq. 11.

$$F = \frac{v_0 - v}{v_0 - v^*} = \frac{y_0 - y}{y_0 - y^*} \quad (11)$$

$$v^* = \frac{\lambda y_0 + v_0}{\lambda/\alpha_c + 1} \quad (12)$$

where, τ is time of the vapor-gas mixture contact in the co-current reactor, s . y_0, v_0 are tritium concentrations (in atomic fraction) in hydrogen and vapor at the inlet of the layer. y^*, v^* are tritium

equilibrium concentrations in hydrogen and vapor at a quit position of the catalyst layer. y, v are concentrations at a quit position in the reactor.

Mass transfer coefficient K_c correlates with the experimental rate constant k_c in the model mentioned above.

$$K_c = k_c \left(\frac{\alpha_c \cdot 2C_V C_H}{\alpha_c C_V + C_H} \right) \quad (13)$$

where C_V and C_H are the vapor and hydrogen concentrations in the space of bed ($\text{mol} \cdot \text{m}^{-3}$).

3 Calculating model

3.1 Mixed bed

3.1.1 Kinetic model

The mixed bed column, operated as a trickle bed reactor, is a packed arrangement containing a mixture of catalytic and inert packing. The bidimensional finite element computing model is used to decrease the computing quantity [9]. The vapor-gas mixture is regarded as a single phase. The steady state concentration profile of specie i is described by Eq. 14 and Eq. 15:

$$G \cdot \frac{dy_i}{dh} = K_i A (Y_i - Y_i^*) = K_i A (Y_i - \alpha_0 x_i) \quad (14)$$

$$L \cdot \frac{dx_i}{dh} = K_i A (Y_i^* - Y_i) = K_i A (\alpha_0 x_i - Y_i) \quad (15)$$

where, Y_i^* and Y_i are T concentration and equilibrium concentration in vapor-gas mixture, respectively.

With the application of finite element model, analytical solution of concentration profile will be obtained. The effective packing height of LPCE column (H) is divided into N finite elements and the bottom element of column is numbered j . The height of finite element is Δh . The schematic of the model is shown in e operating line equation of liquid and gas com [Fig.1. The positions in each finite element is written as Eq. 16.

$$Y_i^* = \alpha_{j,i} x_i = \alpha_{j,i} \left[x_{j-1,i} + \frac{G+V}{L} Y_i - Y_{j-1,i} \right] \quad (16)$$

And Equation 14 can be transformed into Eq. 17.

$$G \cdot dY_i = K_i A \left[Y_i - \alpha_{j,i} x_{j-1,i} - \frac{G+V}{L} (\alpha_{j,i} Y_i + \alpha_{j,i} Y_{j-1,i}) \right] \quad (17)$$

The analytical result of $Y_{j,i}$:

$$Y_{j,i} = \frac{\left\{ \left[e^{\left(\frac{K_i A}{G+V}\right)\left(1-\alpha_{j,i}\frac{G+V}{L}\right)\Delta h} - \alpha_{j,i}\frac{G+V}{L} \right] - \right\}}{1 - \alpha_{j,i}\frac{G+V}{L}} \alpha_{j,i} x_{j-1} \left[1 - e^{\left(\frac{K_i A}{G+V}\right)\left(1-\alpha_{j,i}\frac{G+V}{L}\right)\Delta h} \right] \quad (18)$$

The relationship between concentration of hydrogen phase (y_i) and Y_i at the same position is written as Eq. 19.

$$y_i = Y_i \cdot \frac{1 + \varepsilon}{1 + \alpha_c \varepsilon} \quad (19)$$

The relative concentration ε depends on total pressure and saturated vapor pressure under certain experimental conditions, as Eq. 20

$$\varepsilon = \frac{V}{G+V} = \frac{P_{QTO}^*}{P_{tot}} \quad (20)$$

where, P_{QTO}^* is saturated vapor pressure, P_{tot} is total pressure of bed.

The separation factor of the bidimensional model is:

$$\alpha_0 = \alpha_c \alpha_d \frac{1 + \varepsilon}{1 + \alpha_c \varepsilon} \quad (21)$$

The definition of the global mass transfer coefficient K_i is as Eq. 22, which is related to the each process rate.

$$K_i = \alpha_d \alpha_c / \left(\frac{\alpha_d r_1}{K_c} + \frac{1}{K_c} \right) \quad (22)$$

where, r_1 is the mass transfer rate of catalytic exchange, r_2 is the mass transfer rate of phase exchange.

3.1.2 Computing methods

Mathematical model, describing the mass transform process, uses finite difference to solve coupled differential equations and get the analytical solution. The iterative calculation begins from the bottom to the top of the column. In order to find the right value for the concentration profiles of the three phases (liquid, vapor, hydrogen), the top liquid and bottom hydrogen concentration are given, and a computational accuracy η and initial value of bottom liquid concentration are input. After a few times of Iterative calculations, the value of top liquid concentration is output and compared with the set value. If the computing deviation exceeds expectations, initial value should be adjusted and cycle restarts. The specific method is shown in the Fig.1.

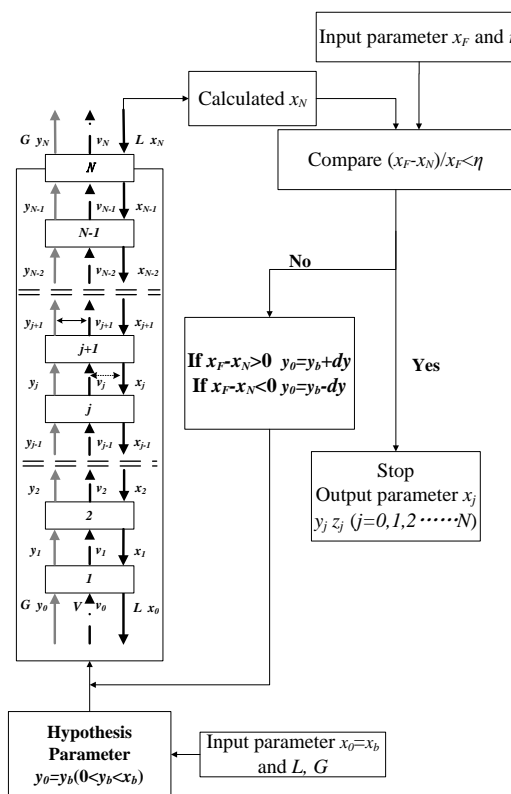

Fig.1 Mixed bed model computational method.

3.2 Separated bed

3.2.1 Kinetic model

The LPCE column packing can also be filled in separated layers, where hydrophobic catalyst and hydrophilic packing are in the continuous interleaved way of packing. As Fig. 2 shows, the whole column is divided into limited number of mass transfer elements. The effective packing height is H and the number of mass transfer elements is $2N$. The height of catalyst exchange layers is h_c , and the height of phase exchange layers is h_s . The layers are numbered from the bottom to the top. In order to study the HIs mass transfer in the LPCE column, the single layers of catalytic exchange and phase exchange are respectively model elements. The description of the mathematical model in the mass transfer unit adopts simultaneous equations, which consist of operating line equations, equilibrium equations and mass transfer efficiency equations.

The transfer process equations of catalytic exchange layer are written as Eq. 23 and Eq. 24.

$$v'_j = -\frac{G}{V_{j-1}} \cdot y_j + \left(\frac{G}{V_{j-1}} \cdot y_{j-1} + v_{j-1} \right) \quad (23)$$

$$v_j'^* = \alpha_G \cdot \frac{y_j^*}{1 + (\alpha_c - 1)y_j^*} \quad (24)$$

The efficiency of catalytic isotope exchange is described as Eq. 25.

$$\eta_{cj} = \frac{y_{j-1} - y_j}{y_{j-1} - y_j^*}$$

$$= \frac{v_{j-1} - v_j'}{v_{j-1} - v_j'^*}$$

$$= 1 - \exp\left(-\frac{K_c h_c A_c \cdot \sqrt{(G/V_{j-1})^2 - 1}}{G}\right) \quad (25)$$

The transfer process equations of phase exchange layer are written as Eq. 26 and Eq. 27.

$$v_j = \frac{L}{V_{j-1}} \cdot x_j + \left(v_j' - \frac{L}{V_{j-1}} \cdot x_{j-1}\right) \quad (26)$$

$$v_j^* = \alpha_d \cdot \frac{x_j^*}{1 + (\alpha_d - 1)x_j^*} \quad (27)$$

The efficiency of phase exchange is described as Eq. 28.

$$\eta_{dj} = \frac{x_j - x_{j+1}}{x_j - x_{j+1}^*}$$

$$= \frac{v_j - v_j'}{v_j^* - v_j'}$$

$$= 1 - \exp\left(-\frac{K_d h_s A_d \cdot \left(1 - \frac{L_j}{V_{j-1}}\right)}{L_j}\right) \quad (28)$$

where, v_j' , $v_j'^*$ and v_j , v_j^* are concentration and equilibrium concentration of tritium in the vapor flow leaving the j-th phase layer and catalyst layer. y_j , y_j^* are concentration and equilibrium concentration of tritium in the gas flow leaving the j-th catalyst layer. x_j , x_j^* are concentration and equilibrium concentration of tritium in the gas flow leaving the j-th phase layer.

3.2.2 Computing methods

At first, determine the concentration of three phases at the bottom of the column. In a steady state of CECE system, concentrations of gas and liquid keep electrolytic dissociation equilibrium, besides, the vapor phase and liquid concentration satisfy the relationship of separation equilibrium, so the initial concentration of hydrogen phase, liquid phase and vapor phase can be evaluated by Eq. 29 to Eq. 31.

$$y_{i,0} = \frac{x_{ele}}{\alpha_{ele}(1 - x_{ele}) + x_{ele}} \quad (29)$$

$$v_{i,0} = \alpha_d \cdot \frac{x_{ele}}{1 + (\alpha_d - 1)x_{ele}} \quad (30)$$

$$x_{i,1} = x_{ele}/\alpha_{ele} \quad (31)$$

where, x_{ele} is the concentrations of electrolyte, α_{ele} is the electrolytic separation factor.

And then, adopt numerical iteration method to calculation the tritium from the bottom to the top until the stoichiometric result of liquid and gaseous phase attending the computing accuracy.

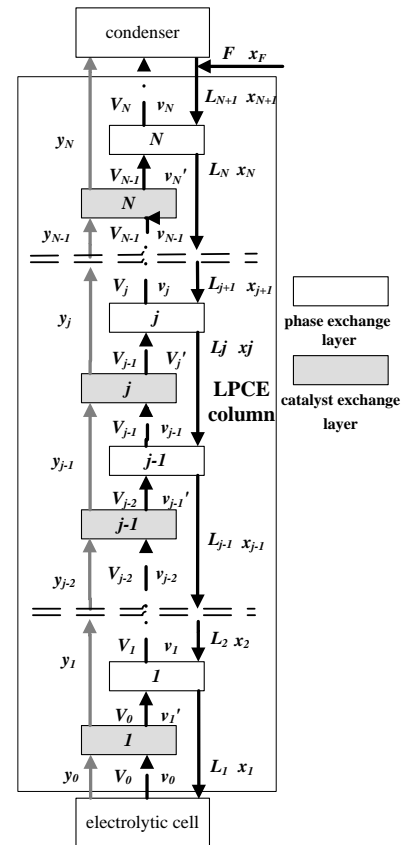

Fig.2 Separated bed computational model.

4 Simulation results and discussion

To test the availability of the mathematical model, in this article, the performance of water-gas catalytic isotopic exchange is analyzed in a LPCE column equipped with two different types of filling: successive mixed and separated layers at low tritium concentration. The object of this study is the column with the diameter of 100mm and height of 2m. The catalyst volume ratio is 20% and the water-wet packing is 80%.The performance of the reaction is expressed by the mass transfer coefficients, with 15.68

$\text{mol/m}^3\cdot\text{s}^{-1}$ (catalytic exchange) and $6.2\text{mol/m}^3\cdot\text{s}^{-1}$ (phase exchange).

The parameters used in the calculation are as follows. Liquid flow-rate L is 0.085mol/s , gas flow-rate G is 0.060mol/s , the reaction temperature is 340K and the reaction temperature pressure is 0.201MPa . The liquid concentration at top of the column is 10^{-6} and the feed gas concentration at bottom of the column y_b is 6.0×10^{-6} .

Figures.3 and 4 present the profiles of tritium concentration along the column for three phases of mixed and separated bed, respectively.

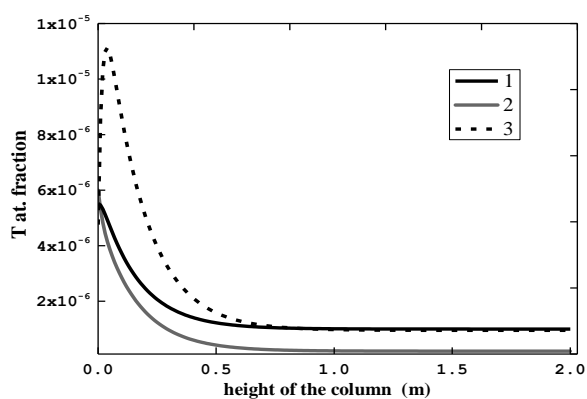

Fig.3 Variation of tritium concentration along the column of mixed bed (1, in water; 2, in hydrogen; 3, in vapor).

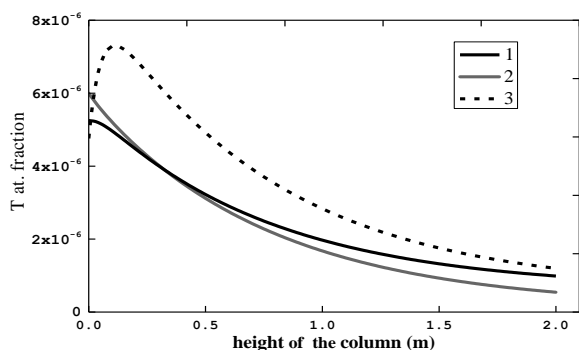

Fig.4 Variation of tritium concentration along the column of separated bed (1, in water; 2, in hydrogen; 3, in vapor).

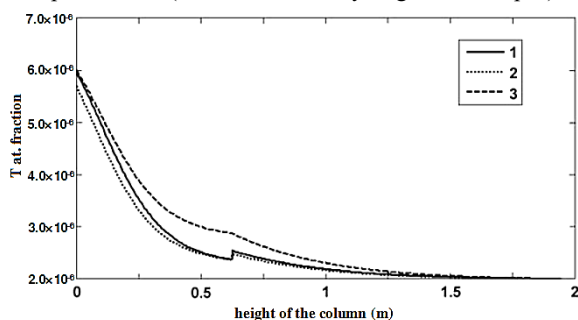

Fig.5 Variation of concentration along the LPCE column in Literature 10 (1, in water; 2, in hydrogen; 3, in vapor).

Although there is lack of relevant experimental data to verify the accuracy of the models further, the models can reflect the characteristics of LPCE column in the hydrogen isotopes mass transfer process compared with literature. By contrast with other model simulation results [10], variation tendency of the profiles of tritium concentration is roughly slightly similar. Compared with the simulation results, mixed bed has better mass transfer coefficient for LPCE column.

5 Conclusion

- 1) The equilibrium and transfer mathematical models of LPCE column of high-performance hydrophobic catalysts can accommodate the mechanisms of mass transfer in packed beds on both two types of package.
- 2) The simulation model allows calculation of isotope profiles in streams of liquid water, water vapor, and gaseous hydrogen along the LPCE column over a very wide range of isotopic compositions.
- 3) Compared with the mathematical models presented in this paper, mixed bed has better mass transfer coefficient for LPCE column.

Acknowledgement

This research was supported by Project of the International S&T Cooperation Program of China [grant number 2015DFR60380]. The authors thank them for the financial support.

References

- [1] AIME Bruggeman JB, and SVEN, Vanderbiesen.: Water Detritiation: Better Sckycen Catalysts for Liquid Phase Catalytic Exchange, Fusion Science and Technology, 2005, 48:102-107.
- [2] BUSIGIN, A.: Mass Transfer Model Liquid Phase Catalytic Exchange Column Simulation Applicable to any Column Composition Profile, Fusion Science and Technology, 2017, 67: 286-289.
- [3] BORNEA, A, PETRUTIU, C, and ZAMFIRACHE, M.: Complex Software Dedicated for Design and Simulation of LPCE Process for Heavy Water Detritiation, Fusion Science and Technology, 2017, 67: 270-273.
- [4] ALEKSEEV lekseev SDB, LA., FEDORCHENKO, O.A., GRUSHKO, A.I., and KARPOV, S.P.: The CECE Experimental Industrial Plant for Reprocessing of Tritiated Water Wastes, Fusion Science and Technology, 2002, 41: 5.

- [5] .BUSIGIN, A., and SOOD, S.K.: Flosheet-A Computer Program for Simulating Hydrogen Isotope Separation Systems, *Fusion Technology*, 1988; 14: 1094-1101.
- [6] OVCHAROV, A.V., ROZENKEVICH, M.B., and PEREVEZENTSEV, A.N.: Simulation of CECE Facility for Water Detritiation. *Fusion Science and Technology*, 2017, 56: 1462-1470.
- [7] SHIMIZU, M., KITAMOTO, A., and TAKASHIMA, Y.: New Proposition on Performance Evaluation of Hydrophobic Pt Catalyst Packed in Trickle Bed. *Journal of Nuclear Science and Technology*, 1983, 20: 36-47.
- [8] SULIMOV, A.V., DANOV, S.M., OVCHAROVA, A.V., OVCHAROVA, A.A., FLID, V.R., and UGRYUMOV, O.V.: Vapor-liquid Equilibrium in the System of Propylene Oxide Synthesis Products. *Theoretical Foundations of Chemical Engineering*, 2015, 49: 854-863.
- [9] BORNEA, A., PECULEA, M., ZAMFIRACHE, M., and VARLAM, C.: Experimental Investigation in Order to Determine Catalytic Package Performances in Case of Tritium Transfer from Water to Gas, *Fusion Science and Technology*, 2017, 48: 116-119.
- [10] OVCHAROVA, A.V., ROZENKEVICH, M.B., and PEREVEZENTSEV, A.N.: Simulation of CECE Facility for Water Detritiation. *Fusion Science and Technology*, 2017, 56: 1462-1470.